

<b>BODY</b> 100' Ascendant Aerial Tower Alum Body COMPT, LEFT SIDE Full Height Lap Doors COMPT, RIGHT SIDE Full Height Lap Doors	<b>WATER TANK</b> 280 Gallon Poly Water Tank Foam System Husky 3 Single Agent Foam System Foam Cell 20 Gallon Foam Cell, Reduced Water
-------------------------------------------------------------------------------------------------------------------------------------------------	-------------------------------------------------------------------------------------------------------------------------------------------------------

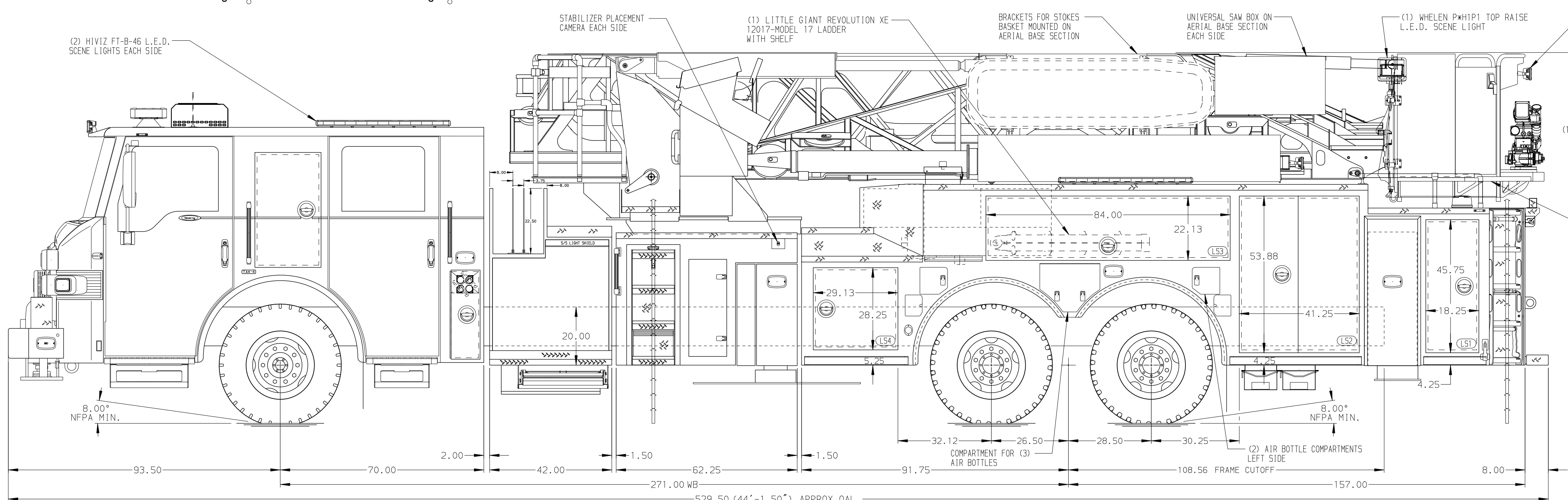

<b>CHASSIS</b> Velocity Chassis (Big Block) <b>ENGINE</b> 605 HP Cummins X15 Engine	<b>CAB</b> 7000 Velocity FR Cab <b>BUMPER</b> 15" Painted Aluminum	<b>AXLE, FRONT, CUSTOM</b> 24,000 Lb TAK-4 Axle <b>AXLE, REAR</b> 54,000 Lb Meritor Axle	<b>TRANSMISSION</b> Allison 5th Gen, 4500 EV5 P	<b>PUMPHOUSE</b> 42" Control Zone Side Mount <b>PUMP</b> 2000 GPM Waterous S100
----------------------------------------------------------------------------------------------	-----------------------------------------------------------------------------	---------------------------------------------------------------------------------------------------	----------------------------------------------------	------------------------------------------------------------------------------------------

**NOTE**  
DIMENSIONS SHOWN ARE APPROXIMATE AND ARE SUBJECT TO MINOR DEVIATIONS AS MAY OCCUR OR BE NECESSARY IN CONSTRUCTION. MINOR DETAILS NOT SHOWN.

- HUSKY 3 RESERVOIR LOCATED PER SHOP ORDER
- SHORELINE RECEPTACLE LOCATED IN THE DRIVER SIDE CAB STEP WELL
- AIR INLET WITH DISCONNECT COUPLING IN THE DRIVER SIDE STEPIWELL
- AIR OUTLET WITH SHUT OFF VALVE LOCATED ON THE DRIVER SIDE PUMP PANEL
- BATTERY CHARGER LOCATED BEHIND DRIVER'S SEAT ON THE EMS COMPARTMENT VERTICAL WALL
- BATTERY CHARGE INDICATOR LOCATED NEAR DRIVER SEAT RISER WITH BRACKET
- L.E.D. LIGHT STRIPS WITH STAINLESS STEEL PROTECTIVE COVER LOCATED IN HOSE BED
- SIX ADJUSTABLE FULL WIDTH/FULL DEPTH SHELVES IN COMPARTMENTS PER SHOP ORDER
- ONE ADJUSTABLE TILTING SLIDE-OUT TRAY IN COMPARTMENT PER SHOP ORDER

- THREE FLOOR MOUNTED SLIDE-OUT TRAYS IN COMPARTMENTS PER SHOP ORDER
- TWO SLIDE-OUT TOOL BOARDS WITH PEGBOARD PATTERN MOUNTED TO SLIDE-OUT TRAY IN COMPARTMENTS PER SHOP ORDER
- TWO SPECIAL HEIGHT VERTICAL PARTITIONS IN COMPARTMENTS PER SHOP ORDER
- ONE NYLON STRAP RETENTION WEBBING IN COMPARTMENT PER SHOP ORDER
- XANTREX INVERTER LOCATED PER SHOP ORDER
- CIRCUIT BREAKER PANEL LOCATED PER SHOP ORDER
- FOUR 120V DUPLEX RECEPTACLES LOCATED IN CAB PER SHOP ORDER
- FOUR 120V DUPLEX RECEPTACLES LOCATED IN COMPARTMENT PER SHOP ORDER
- DC POWER TO AERIAL BASKET

- FIRE RESEARCH 3-WAY INTERCOM SYSTEM BETWEEN AERIAL TIP, PUMP PANEL AND TURNTABLE
- NON-RAISED AERIAL PEDESTAL
- 3-IN-1 LYFE BRACKETS ON BASKET

REV	DATE	BY	CH	VELOCITY
07DEC21		TKA	DTJ	

		JOB NO.	36820
		SCALE	DATE
TITLE	100' ASCENDANT AERIAL TOWER AND BODY ASSEMBLY	DRAWN BY	TKA
FOR	SAUK CITY FIRE DEPARTMENT SAUK CITY, WISCONSIN	CHECKED BY	NDA
DWG NO.	36820AD	SHEET SIZE	SHEET NO.
		D	1 OF 1